

# Loon

## Installation Manual

*Estevan Meter*  
www.estevanmeter.com  
(306) 634-5304

**Estevan Meter Services LTD**  
Estevan, SK, Canada  
S4A 2A4



Manufactured in Canada

**Phone** (306)-634-5304

**Web Site** [www.estevanmeter.com](http://www.estevanmeter.com)

**E-Mail** [reception@estevanmeter.com](mailto:reception@estevanmeter.com)

## **Estevan Meter Services LTD**

### **Loon Card**

#### **Warranty Statement**

WARRANTY: Estevan Meter Services LTD warrants all equipment of its own manufacture to be free of defects in material and workmanship for a period of twelve (12) months from date of shipment. Estevan Meter Services LTD's sole obligation hereunder shall be expressly limited to repair or exchange free of charge, F.O.B. Estevan, Saskatchewan, Canada, of such defective equipment (alternatively, Estevan Meter Services LTD will, at its option, refund the purchase price). Estevan Meter Services LTD's obligation under this warranty is limited to the above and does not apply to exchange or repairs which are required as a result of improper installation, misuse, maladjustment, abnormal operating conditions, or lack of routine maintenance. Nor does the warranty include the furnishing of service for maintenance or problems arising from the foregoing causes. No claims for labour, installation, removal, transportation, or other expenses will be recognized. Notwithstanding any stipulation of the purchaser to the contrary, all other obligations, representations, warranties, and conditions, express or implied, statutory or otherwise, including any implied warranties or conditions of merchantability, quality or fitness are hereby excluded and Estevan Meter Services LTD shall not be liable for any loss, cost, or damages of any kind whatsoever, whether consequential, indirect, special, or otherwise, arising out of or in connection with the equipment or any defect therein, even if caused by the negligence of Estevan Meter Services LTD, its employees, or agents. The provisions hereof relating to the warranty and limitations hereon and limitation of liability shall continue to be enforceable between the parties notwithstanding termination of the within agreement for any reason including fundamental breach. Equipment not of Estevan Meter Services LTD manufacture will carry the vendor's or manufacturer's standard warranty.

© 2017 Estevan Meter Services LTD

## INDEX

I	Warranty	3
II	Proprietary Information	3
III	Design and Manufacturing Support Team	3
1.0	Introduction	4
2.0	Functional Specifications/Features	4
3.0	Theory of Operation	5
4.0	Jumpers	6
5.0	Installation	6
6.0	Software Description	7
7.0	Trouble Shooting	9
8.0	Schematics	10
	Programming the 4-20mA Option	11

## **I Warranty**

Estevan Meter Services LTD warrants all equipment of its own manufacture to be free of defects in material and workmanship for a period of twelve (12) months from date of shipment. Estevan Meter Services LTD's sole obligation hereunder shall be expressly limited to repair or exchange free of charge, F.O.B. Estevan, Saskatchewan, Canada, of such defective equipment (alternatively, Estevan Meter Services LTD will, at its option, refund the purchase price). Estevan Meter Services LTD's obligation under this warranty is limited to the above and does not apply to exchange or repairs which are required as a result of improper installation, misuse, maladjustment, abnormal operating conditions, or lack of routine maintenance. Nor does the warranty include the furnishing of service for maintenance or problems arising from the foregoing causes. No claims for labour, installation, removal, transportation, or other expenses will be recognized. Notwithstanding any stipulation of the purchaser to the contrary, all other obligations, representations, warranties and conditions, express or implied, statutory or otherwise, including any implied warranties or conditions of merchantability, quality or fitness are hereby excluded and, Estevan Meter Services LTD shall not be liable for any loss, cost or damages, of any kind whatsoever, whether consequential, indirect, special or otherwise, arising out of or in connection with the equipment or any defect therein, even if caused by the negligence of, Estevan Meter Services LTD, its employees or agents. The provisions hereof relating to the warranty and limitations hereon and limitation of liability shall continue to be enforceable between the parties notwithstanding termination of the within agreement for any reason including fundamental breach. Equipment not of, Estevan Meter Services LTD manufacture will carry the vendor's or manufacturer's standard warranty.

## **II Proprietary Information**

The information disclosed herein contains proprietary rights of Estevan Meter Services LTD Neither this document nor the information disclosed herein shall be reproduced or transferred to other documents, or used or disclosed to others for manufacturing purposes, or for any other purpose except as specifically authorized in writing by Estevan Meter Services LTD

## **III Design and Manufacturing Support Team**

Designed by: Jim Janke

Printed Circuit Board Design: John Wheeler

Product Testing: Jim Janke

Software Development: Jim Janke

Manual: Jim Janke and Sylvia Track

Product Production Manager: Jim Janke

## **1.0 Introduction**

The Loon was designed to monitor a tank level and record/indicate changes in that level. This unit has three different ways of outputting the current tank level. The first is an Up Pulse and Down Pulse Output. Two open collector outputs can indicate either a positive or negative direction of level movement. Each pulse indicates a specific level change of a certain distance. Communications are the second way that the Loon can transmit a level. Using an SV Bus the Loon can have values loaded to it and values received from it. After the host has loaded a value to the Loon, it can keep reading it for constant level updates. An isolated 4 to 20mA current output is also available. The output will be scaled between a low and high level which can be entered via the SV communications bus. A battery input is also available on the Loon. In normal operating conditions, the battery will be trickle charged, but if power fails, the battery will sustain power to the unit to monitor the level until main power is returned.

## **2.0 Functional Specifications/Features**

- can replace the The Grimes Tank Level Unit
- 8 to 30 VDC operation
- backup battery input with trickle charge feature
- SV bus communications
- isolated 4-20mA current loop output
- pulse output capabilities
- -40°C to +60°C operation
- low power consumption (under 15mA with no battery charging)
- all input and output lines are transient suppressed
- uses a lower power, low voltage PIC 6LC73A microcompressor
- selectable addresses for the Communication Mode
- optocoupled received inputs
- 5% to 95% relative humidity, noncondensing

- SV Bus communication

### 3.0 Theory of Operation

Refer to Loon Schematics

8 to 30 Volt DC power is needed to be provided to the loon by the way of P1 pins 3 and 5. This input voltage has three purposes. The first is to provide power to the battery trickle charge system. T1 and T2 act as a 20mA regulator to charge up the battery. T2 is used for regulation and T1 is used for current limiting. If a battery is low, the trickle charge circuit will provide 20mA to the battery until the battery reaches 6.5 Volts. The charge current will start to decrease as the battery voltage increases. The battery when fully charged will always require some input current to compensate for its own self discharge. Power is also required for running the communication section. The receive optocoupler gets its power directly off of the input supply. If power is lost from the host, D2 prevents the battery from providing power to the communication section. The PIC16LC73A microprocessor and supporting components get their power from VR1, a micropower 3.3 Volt regulator. These components are transient suppressed with CR3, a 5V Transorb. C5, C6, and C7 provide noise filtering to the input and output of the regulator.

The optical Interrupters (K1 and K2) convert the wheel rotation into electronic signals. As the disk rotates the black bands on the disk will interrupt the light going from the LED to the phototransistor. This will turn the phototransistor off pulling pin 3 high. Clear sections of the disk will allow the light to pass through turning the transistor on driving pin 3 to ground. The space between these interrupters is critical. With the proper spacing, the interrupters will give a 90 degree phase shift on the output when the disk is rotated. The direction of the disk rotation will be indicated by which interrupter provides the leading or lagging pulse. Because it is possible for the black bands on the disk to partially turn on the optointerrupters, rise and fall times of the optointerrupters can be very slow. To allow for this, a schmitt trigger input flip-flop arrangement was used to square up the pulses for the microprocessor. The PIC18LC73A has the ability to detect a change of state on the upper four pins of Port B. The software then has the ability to sample the state of the two pins RB6 and RB7, and detect what change has taken place since the last sample. It can then be determined which direction the disk has turned. The Loon will turn off the appropriate up or down FET, (Q2 or Q3), for 500uS. P1 pins 6 and 7 lines go from a normally on state and turn off. A file memory register will either be incremented and decremented depending on the direction of the disk movement. The Loon can have the value of its registers read or written to as described in the software description Section. When any

member on the SV bus communicates, all other devices on the bus will receive the transmission.

A 4 to 20mA analog output section is available for the user to get a scaled output for a tank level. The 12 bits of resolution are serially loaded in using the Din and Calk line of the LTC1257 Digital to Analog Converter (DAC). After the 12 bits are shifted in a Load pulse is sent to latch the data in and output the appropriate analog output signal. The DAC has a reference of 2.048 volts which is used for establishing a constant 4mA output signal. The DAC Volt pin will output 0 volts when loaded with 0 serially and 2.048 volts when loaded with 2048 (FFF HEX). This output acts as the span and creates up to 16mA of additional current. The regulator for this section gets its power from the loop power source. This allows the Loon to act as a sinking or sourcing type device. All quiescent current from the circuit goes through a 50 ohm sense register allowing the circuits quiescent current to make up some of the base 4mA. The additional current for the 4mA and the span of 16mA is provided by T3.

#### 4.0 Jumpers

The following is a list of jumpers and their function. If any of the jumpers is changed, it is recommended that the Loon have its power removed and then be powered again. The new jumper settings will be scanned on power up.

J1 to J4 ? J1 to J4 set the address of the Loon that the host system will communicate to. A maximum of 8 Loons should be connected to one host at any one time. Address 0 is an invalid address.

<b>ADR</b>	<b>J1</b>	<b>J2</b>	<b>J3</b>	<b>J4</b>
1	out	in	in	in
2	in	out	in	in
3	out	out	in	in
4	in	in	out	in
5	out	in	out	in
6	in	out	out	in
7	out	out	out	in
8	in	in	in	out

#### 5.0 Installation

The Loon has been equipped with four mounting holes to mount the case inside a Class 1, Division 1 Electrical Enclosure. The centre of the card should be aligned with the centre of the disk shaft. Deviation of these two centre points

should not exceed 0.05 inches. Large misalignments could cause improper optointerrupter sensing.

All wires to be brought inside this case should be between 22 gage and 18 gage stranded wire. Two conductors will be used to provide power to the loon. If Pulse Mode is required, two wires are required for the UP and DOWN pulses. Communication Mode only requires a single wire. This wire will be connected to P1 pin3. If a 6 Volt lead acid battery is being used, two wires will have to be connected to P2, pins 1 and 2. Each unit should be bench tested before installation out in the field. Possible problems with the opticalinterrupters can be resolved at this point. It should be noted that different resolution of light interrupter disks can be used with this card. Below is a list of these disks.

- 52 pulse disk –1.0 cm resolution
- 90 pulse disk – 0,57777777 cm resolution
- 104 pulse disk – 0.5 cm resolution

Either Current level in CM, the Level/Volume scaler, or the Level/Level scaler register will have to be set up in the Raven card.

## **6.0 Software Description**

### **Basic Operation:**

All of the monitoring of the optical interrupters is done through interrupts in software. When RB5 or RB6 of the PIC16LC73A microprocessor change state an interrupt will occur. The microprocessor will jump out of its existing code and read RB5 and RB6. By comparing the previous state and the present state of these inputs, it can be determined which direction the disk is travelling in. Either the Up or Down open collector output will get turned off. The level count may be incremented or decremented depending on the direction of travel. The software will then break out of the interrupt routine and operate in the main program loop. The main program loop in software involves doing calculations for the 4mA to 20mA transmitter. File Registers 2 and 3 are used for these calculations. Any Level Count less than the value stored in File Register 2 will equal 4mA and any value greater than File Register 3 will equal 20mA. Outputting this properly scaled value for the digital to analog converter is also done in the main program loop. The 4mA to 20mA transmitter are updated 10 times a second. Using an internal UART, the Loon scans looking for an instruction from the host using the SV Bus protocol and responding to it. The host can send one of two instructions: load a level register value and receive a level register value. The next section will describe the protocol in more detail.

### **SV Bus Protocol:**



The SV bus protocol is a 3 wire current loop communication method. Communications will be performed at 1200 baud using ASCII characters. A single wire is used to transmit and receive. All communications to and from the host will start off with a command byte. If the host is sending the command byte, then the byte will be capitalized. All command responses from the Loon will be in lower case. An 8 bit check sum is performed on all communications. This check sum is derived by adding up all the ASCII bytes sent, taking the eight least significant bits and complementing them. Below is a list of host commands with the desired responses from the Loon.

#### L? Load Command

The Load Command is used to initialize the Loon to a specific value. The byte transfer format goes as follows:

Host sends L, A, F, B1, B2, B3, B4, Ch, Cl

Host receives l, a, f, b1, b2, b3, b4, ch, cl

where L= an ASCII "L" is transmitted by the host to signify a load command

l= an ASCII "l" is received by the host to indicate a load command response

A= The card address of the Loon that the host wishes to load the value to. This address must be between 1 and 8

F= The file register in the Loon that the value is to be written to. The Loon only uses the following registers. More registers are available for future use.

File Register 1-Level Count

2-4mA Level

3-20mA Level

B1-B4= The Byte Value that is to be loaded into the register. B1 is the M.S.B. and B4 is the L.S.B. The value that will be loaded will be between -32368 and 32767

Ch, Cl= A high and low byte check sum is transmitted at the end of the packet so the device receiving the packet can check its validity.

#### R? Read Command

The Read Command allows the host to monitor the level of the tank. The Loon will respond with a value relating the present level of the tank to the level of the tank when a value was loaded to the Loon.

Host Sends R, A, F, Ch, Cl

Host receives r, a, f, b1, b2, b3, b4, ch, cl

Where R= An ASCII "R" is transmitted by the host to signify a Read Command.

- r= An ASCII “r” is received by the host to indicate a read Command response
- A= The card address of the Loon that the host wishes to load the value to. This address must be between 1 and 8.
- F= The file register in the Loon that the value is to be read from. The Loon only uses the following registers. More registers are available for future use.
  - File Register 1-Level Count
  - 2-4mA Level
  - 3-20mA Level
- B1-B4= The Byte Value that is to be loaded into the register. B1 is the M.S.B. and B4 is the L.S.B. The value that will be loaded will be between -32768 and 32767.
- Ch, Cl= A high and low byte check sum is transmitted at the end of the packet so the device receiving the packet can check its validity.

## 7.0 Troubleshooting

Finding a problem with the Loon can usually be a straightforward task. Below is a list of problems and possible solutions to those problems:

**Problem:** Communication to the Loon is not taking place.

**Check:** Is the address of the Loon correct?

**Problem:** Communication to the Loon is good but the values being returned are inaccurate.

**Check:** The optical interrupters for proper phase adjustment.

**Problem:** No pulse output readings are occurring or the readings are inaccurate.

**Check:** The optical interrupters for proper phase adjustment. In Pulse Output mode, jumper J5 will have to be in.

If problems still persist, contact Estevan Meter Services LTD and we will be pleased to be of assistance with questions or troubleshooting.

## 8.0 Schematics

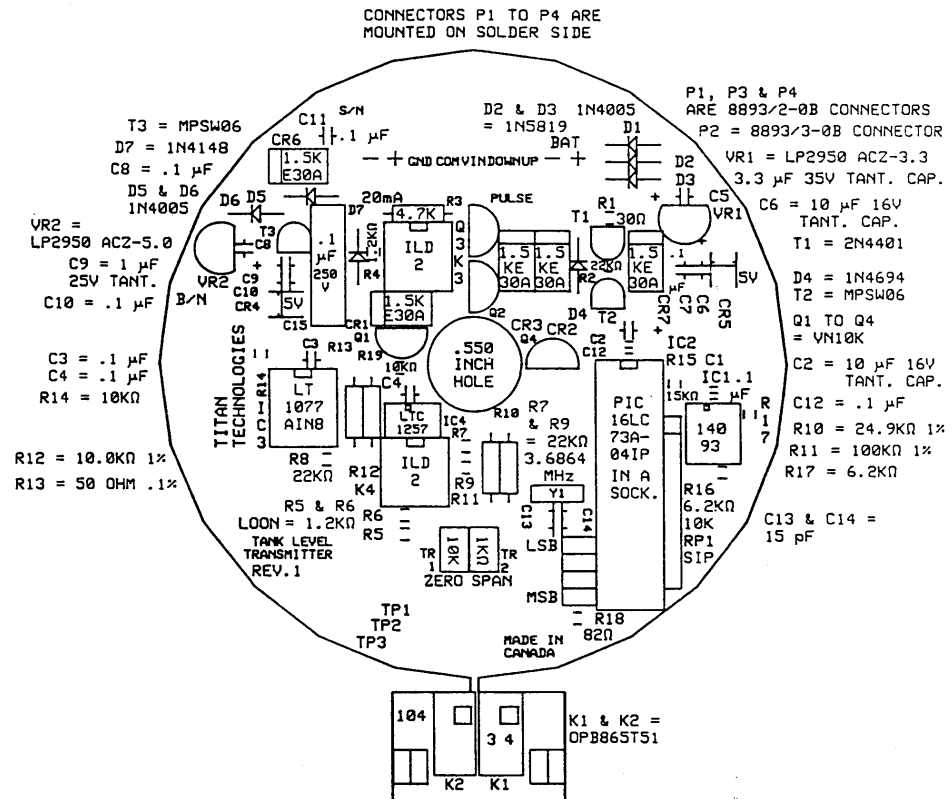

COMPONENT DIAGRAM  
LOON REV. 1

## PROCEDURE FOR PROGRAMMING LOON 4-20mA OPTION

1. Ensure **LOON** software is installed on an IBM compatible PC running Windows version NT, 95, or 98.
2. Verify correct LOON wiring with reference to manuals.  
ie. **RED – POWER**  
**BLACK – GND**  
**VIOLET – COMMUNICATIONS**  
**BROWN – 4-20mA POWER**  
**WHITE – 4-20mA RETURN**

**NOTE:** The 4-20mA loop may be powered by the main power supply or by an isolated source.

3. The **SV-RS232** converter can now be wired as shown below, and the D9 RS232 end can be connected to the communications port:

ie: **WHITE – POWER**  
**SHIELD – GND**  
**BLACK – COMMUNICATIONS**

4. Power up the system and run the **LOON Configuration Software** through windows. The software will select which communications port is being used. Click on the tab to select the correct LOON address (1-8). If **“NO DATA RECEIVED/TIME OUT ERROR”** appears, the wrong address has been selected or the system is not wired correctly.
5. When communication is achieved, the **CURRENT VALUE** for the actual level, 4mA level and 20mA level and will all be set at zero. **Actual levels** refer to the height of product in the vessel while the **20mA** level relates to the maximum height of the tank. The **4mA level** is usually set to zero. All these levels are measured and programmed in cm only. This is done by selecting, with the mouse, the **desired value** box for each setpoint, and entering the measured heights. When one desired value has been entered, **press return**. The number you entered will transfer over to the corresponding **“current value”** box. When all three current value boxes are correct, the 4-20mA will be set for the tank level.

**NOTE:** Due to the smaller physical size of **RIG** and **TANK** gauges, all values entered must be doubled. Ie. If the tank height is 172 cm, the value must be entered as 344cm as the **20mA level**.